

Pile Turner Machine Introduction



FZ1200/1200A/1700

玉田元创包装机械制造有限公司

Yutian UANCHOR Packaging Machinery Co., Ltd.

Company profile



Yutian UANCHOR Packaging Machinery Co., Ltd. which is a professional manufacturer. The company was set up in 2006 in Yutian County, Hebei Province, which is about 80 minutes drive from Beijing international airport. It is covered an area of 2000 square meters with more than 120 employees, among whom more than 20 technical engineers are college-educated and 10 technical research and development personnel with more than 15 years' working experience. The company is abundant in technical force and advanced in making and detecting equipment with excellent management system. Meanwhile, our leading products obtain CE certification in 2011. Our enterprise obtains ISO9001:2008 in 2012 year. In 2013, our company obtains Hebei province enterprise technology center and also obtains the high-tech enterprise in 2014.

We do our best to be the leader in the field of packing machinery innovation and to build the world famous brand. We believe we can make friends all of the world with our honesty and trustworthiness!



玉田元创包装机械制造有限公司

Yutian UANCHOR Packaging Machinery Co., Ltd.

Honor and CE

 <p>高新技术企业 河北省科技厅 河北省财政厅 河北省国家税务局 河北省地方税务局 二〇一四年第20016号</p>	 <p>河北省 企业技术中心 省发展改革委 省科技厅 省财政厅 省国税局 省地税局 石家庄海关 二〇一三年十一月</p>	 <p>中国文教体育用品协会第七届理事会 理事单位 中国文教体育用品协会 二〇一三年六月</p>	 <p>中国文体协会扑克牌专业委员会 ZHONGGUO WEN TI XE HUI PU KE PAI ZHUAN YE WEI YUAN HUI 会员单位 有效期至2015年12月</p>
			
			
 <p>CHTC 质量管理体系认证证书 玉田元创包装机械制造有限公司 认证范围: 分切机的设计开发、生产和销售。 标准: GB/T 19001-2008/ISO 9001:2008 认证日期: 2012年04月24日 有效期至: 2015年04月23日</p>		 <p>Certificate No.: CE-C-1212-11-88-01-2A Date of issue: 2012.03.16 Certificate of Conformity With the requirements of the Machinery Directive 2006/42/EC Name and address of the manufacturer: Yutian Uanchor Packaging Machinery Co., Ltd. Product description type: Automatic Card Slitting & Crimping Machine Applicable standards: EN 1010-3:2002+A1:2009 Safety of machinery - Safety requirements for the design and construction of printing and paper converting machines - Part 3: Cutting machines Technical file ref. no.: YF-C-1212-11-88-01-2A Approved by: Brian Cai - Deputy to Managing Director Date: 18.03.2012</p>	

Workshop



玉田元创包装机械制造有限公司
Yutian UANCHOR Packaging Machinery Co., Ltd.



- **Ensures that the press can be run as a single-man operation**
No longer any need for the operator to take 20 mins to turn a pile. Why pay an assistant?
 - **No Health and Safety issues from back injury**
Less time off work. End of manual handling.
 - **Press keeps running longer between blanket cleans**
Cost benefit.
 - **Any member of the company can operate the pile turner**
Doesn't have to be the press operator (normally one of the most highly-paid members of staff)
 - **Enables the press to be run consistently at higher speeds**
Greater productivity. More sheets on the floor.
 - **1 minute to turn a pile, 3-5 minutes to turn, air and jog a pile**
Far less down-time. More jobs run during a shift. Cost benefit.
 - **Pay-back period can be as short as 3 years**
Stopping the printing press for 20 mins every time. while the operator is on his knees turning the pile costs is high! Repeat this with every pile during the day! Pay-back period of pile turner machine can be as short as 3 years.
 - **No on-going costs**
1 year warranty, thereafter no servicing or maintenance.
- Factor in jobs which might be rejected by a trade laminator**
These are the jobs which have to be put through the press again to remove excessive spray powder – an expensive use of the press. Pile turner will do this!

玉田元创包装机械制造有限公司
Yutian UANCHOR Packaging Machinery Co., Ltd.

I、Device name&Model :Pile Turner FZ1200/1200A/1700

II、General View

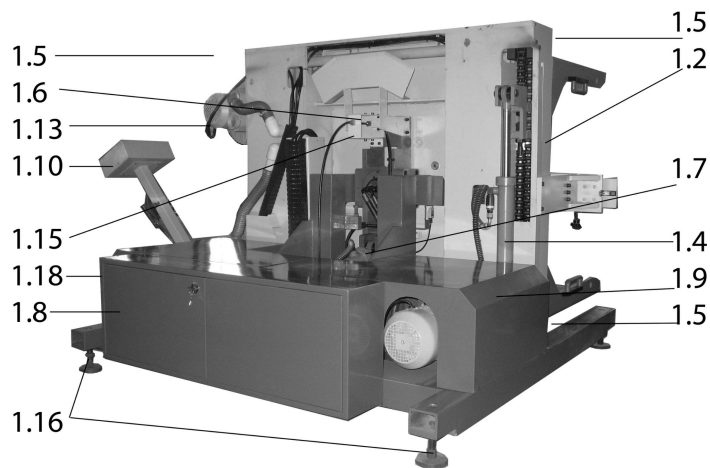
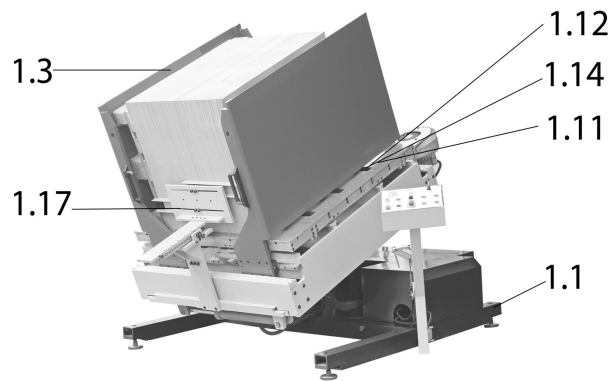

1.1 Base frame 1.2 Fork housing 1.3 Platforms 1.4 Clamping Cylinder for the Driver for the Platforms 1.5 Chain wheels 1.6 Pivot bearing 1.7 Tilting cylinder 1.8 Control cabinet 1.9 Hydraulics 1.10 Control panel 1.11 Ventilation plate 1.12 Aerating device 1.13 Blower motor 1.14 Ventilation system 1.15 Locking mechanism 1.16 Levelling feet 1.17 Jogging ruler 1.18 Main Switch

玉田元创包装机械制造有限公司
Yutian UANCHOR Packaging Machinery Co., Ltd.

III、Specification

Model	FZ1200	FZ1200A	FZ1700
Max.paper weight	1200kg	1400kg	2500kg
Max.paper size	1200*800mm	1200*800mm	1700*1200mm
Min.paper size	560*360mm	560*500mm	600*500mm
Open width	Max.1640mm	Max.1920mm	Max.1900mm
	Min.760mm	Min.920mm	Min.1200mm
Total power	9kw	9kw	17kw
Power supply	3P 380V 50Hz		
Net weight	2800kg	3600kg	4500kg
Dimension	2370*2090*2100mm	2900*2090*2200mm	3170*2550*2400mm

IV、Features

1.Dust removing

Before printing, the paper fibers, paper scraps and dusts will be removed to improve the printing quality and lower the rejection rate. By the way, it can stop the dusts into the printing machine to increase the service life of printing machine.

After printing, removing printing power, speeding the ink drying, separating papers and dirty in back paper can be achieved.

2.Separation of paper

After the vibration and air jetting, the pile is filled with air cushion between of the sheets, in this way, mis-feeds can be avoided.

3.Aligning

With the vibration platform and high pressure blower, the whole pile paper can be aligned at one time.

4.Static remove(optional)

Air with ionized air reduces the electrostatic charge which may affect the finishing process of coated and printed paper or plastic foil.

5.Odor Neutralizing

Very important for food packaging

6.Turning

For the piles of double-sided printing paper, the pile turning will improve the work efficiency and lower the intensity of work. The working environment will be much better for workers.

7.High efficiency easy operation

For average, the turning, powder removing, separation of paper and aligning, the processes takes about 3-5 minutes.

Everyone can handle the machine.

V、Function:

This machine contains three functions: turning, jogging and ventilation. The

玉田元创包装机械制造有限公司

Yutian UANCHOR Packaging Machinery Co., Ltd.

machine is necessary auxiliary equipment in the printing process, it not only make the paper stack turned over automatically, but also make the stack tidy. Importantly it can save in labors and avoid impact on the printed surface.

VII、Warranty

The machine warranty is for one year ,we free offer the parts which are normal operation of the damage not including man-made damage except consumables during the guarantee period .

Machine installation:

An engineer installation and training time is about two days.

The buyer is responsible for an engineer's round-trip air tickets, meals and hotels.

IX、Flow chart

工作流程图 / Working Flow Chart

1、用液压车将纸堆推入整理机内如图。
Put the pile into platform of pile turner with hydrasulic trolley.



2、整理机翻起、旋转、倾斜如图。
Turning up, rotating, tilting.



3、打开整理机吹风、振动按钮，对纸堆进行除尘（除去纸毛、纸屑、灰尘）、松纸、齐纸、还可翻转。
Switch on the air jetting and vibration to remove dust (paper fiber, paper scraps) separate the sheets, aligning r & turning paper pile.



4、整理机回位、放下，用液压车将纸堆取走，如图。
The pile turner will come back to its origin position, turn down. The pile can be taken out by the hydraulic trolley.



玉田元创包装机械制造有限公司
Yutian UANCHOR Packaging Machinery Co., Ltd.

1. Electrical detail

Parts	Model	No.	Country	Brand
两级断路器 Two-stage circuit breaker	BKN 2P D16A	1	Korea	LS
自动空气开关 Automatic air switch	GLK11-40 combination switch(40A)	1		
可编程序控制器 PLC	CP1E-N40SDT-D (Battery attached)	1	Japan	OMRON
三级断路器 Three-stage circuit breaker	BKN 3P D16A	2	Korea	LS
三级断路器 Three-stage circuit breaker	BKN 3P D10A	2	Korea	LS
交流接触器 AC contactor	LC1-D1210M7C	1	France	Schneider
浪涌抑制器 Surge suppressors	LAD-4RCU	1	France	Schneider
热继电器 Thermal relay	LRD14C 7-10A	1	France	Schneider
稳压电源 Regulated power supply	S8FS-C15024	1	Japan	OMRON
继电器 Relay	RJ2S-CL-D24 RJ2S-07L	7	Japan	IDEC
风机变频器 Fan frequency converter	4K00-3P4-MNA-XX 4KW	2	Germany	Rexroth
电机变频器 Toshiba Converter	0K40-3P4-MNA-XX 0.4KW	2	Germany	Rexroth
绿色带灯按钮 Green button with light	XB2BW33B1C	1	France	Schneider
白色按钮 White button	ZB2-BA1C ZB2-BZ101C	1	France	Schneider
绿色按钮 Green button	ZB2-BA3C ZB2-BZ101C	2	France	Schneider

玉田元创包装机械制造有限公司
Yutian UANCHOR Packaging Machinery Co., Ltd.

黑色按钮 Black button	ZB2-BA2C ZB2-BZ102C	2	France	Schneider
工停按钮 Stop button	ZB2-BS44C ZB2-BZ104C	1	France	Schneider
两位选择按钮 Two selection buttons	ZB2-BD2C ZB2-BZ105C	1	France	Schneider
红色指示灯 Red light	XB2BVB4LC	1	France	Schneider
三位选择按钮 Three selection buttons	ZB2-BJ5C ZB2-BZ103C	2	France	Schneider
限位开关 Limit switch	TZ-5104	2	Taiwan	TEND
接近开关 Proximity switch	TL-Q5MC1	3	Japan	OMRON

2.Key parts

Parts	Model	No.	Country	Brand
高压风机 High pressure air blower	RJ-629	2	China	RJ
阪神减速电机 Gearmotor	WM040-020-100SM 6P	1	Japan	TPG
振动电机 Vibrating motor	DEG MVE300-3YT(0.25KW)	1	Italy	OLI-WOLONG
振动电机 Vibrating motor	DEG MVE300-3YT(0.25KW)	1	Italy	OLI-WOLONG
直线导轨 Linear Guides	BGCH45FE2L950NZ0 II	4	Taiwan	STAF
液压站 Hydraulic station		1	Italy	Oiltec
锥度接头 Taper joint	R3/4 change M20*1.5	2	Italy	Oiltec
锥度接头 Taper joint	R1/2 change M20*1.5	2	Italy	Oiltec
锥度接头 Taper joint	M18*1.5 change M20*1.5	2	Italy	Oiltec

玉田元创包装机械制造有限公司
Yutian UANCHOR Packaging Machinery Co., Ltd.

夹紧液压缸 Clamping hydraulic cylinder	CHSGCA63-480A	1	Japan	SMC
翻转液压缸 Turn over hydraulic cylinder	CHSGCA100-552	1	Japan	SMC
I型单轴节接头 Uniaxle joint	IS08139-KJ27D	1	Japan	SMC

3.Spare parts

Part	No.	Part	No.
内六角扳手 Inner hexagon spanner	1	可摇手柄 Rocking handle	1
活动扳手 Adjustable wrench	1	5号丁字扳手 No.5 T-wrench	1
手动控制按钮盒 Manual control button box	1	垫板 Backing plate	10
地胶垫 Floor mat	4	十字螺丝刀 Cross screwdriver	1
坡度板 Gradient board	1	工具箱 Tool box	1
Φ50 风管 Air duct	3 meters	变频器说明书 Instructions for frequency converters	1
膨胀螺栓 M10*80 Expansion bolts	10	翻转机使用说明书 Instructions for using of pile turner	1
O型密封圈 11*1.9 Seal ring	10	零件图册 Parts book	1
组合垫圈 25*18*2 Combined washer	10	电器原理图 Electrical schematic diagram	1
固定板 Fixed plate	4	出厂合格证 Certificate before leave the factory	1
平爆螺钉 M8*20 Flat detonating screw	6		

玉田元创包装机械制造有限公司
Yutian UANCHOR Packaging Machinery Co., Ltd.

Pictures



玉田元创包装机械制造有限公司
Yutian UANCHOR Packaging Machinery Co., Ltd.

CE Certification

	
<h1>CERTIFICATE</h1>	
<h2>ATTESTATION</h2>	
<h3>CERTIFICATE OF MACHINERY AND LOW VOLTAGE DIRECTIVES</h3>	
Technical file of the company mentioned below has been observed 2006/42/EC Machinery Directive and 2014/ 35/EU Low Voltage Directive have been taken as references for these processes	
Company Name	: Yutian Uanchor Packaging Machinery Co., Ltd.
Company Address	: Zhenyu Road 669#,Xinxing Industry Zone,Yutian,Hebei,China
Related Directives and Annex	: Low Voltage Directive 2014/35/EU Machinery Directive 2006/42/EC
Related Standards	: EN ISO 12100:2010,EN 1010-1:2004+A1:2010 EN ISO 4413:2010,EN 60204-1:2006+A1:2009+AC:2010
Product Name	: Pile Turner
Report No and Date	: TCF201708180124-S:18.08.2017
Product Brand/Model/Type	: FZ-1200,FZ-1200A,FZ-1700
Certificate Number	: M.2016.201.N1869
Initial Assessment Date	: 21.08.2017
Registration Date	: 22.08.2017
Reissue Date/No	: -
Expiry Date	: 21.08.2022
<small>The validity of the certificate can be checked through www.udemltd.com.tr. The CE mark shown on the right can only be used under the responsibility of the manufacturer with the completion of EC Declaration of Conformity for all the relevant Directives. This certificate remains the property of UDEM International Certification Auditing Training Centre Industry and Trade Co. Ltd. to whom it must be returned upon request. The above named firm must keep a copy of this certificate for 15 years from the registration of certificate. This certificate only covers the product(s) stated above and UDEM must be notified in case of any changes on the product(s)</small>	
Address: Mutlukent Mahallesi 2073 Sokak (Eski 93 Sokak) No:10 Çankaya – Ankara – TURKEY	
Phone: +90 0312 443 03 90 Fax: +90 0312 443 03 76	
E-mail: info@udemltd.com.tr www.udemltd.com.tr	
 UDEM International Certification Auditing Training Centre Industry and Trade Co. Ltd.	
 	